

SYMPTOMS	PROBABLE CAUSES	SUGGESTED REMEDIES
DEAD BATTERY	Key switch left on	Turn key off, recharge battery
	Bad battery	Replace battery
	Shorted starter solenoid	Replace starter solenoid
BATTERY WONT CHARGE	Loose or corroded battery connection	Clean and tighten connections
	Defective voltage regulator	Contact local service center
	Dead battery cell	Turn key on and pull rope to start engine. Replace battery as soon as possible
	Worn out or defective battery	Turn key on and pull rope to start engine. Replace battery as soon as possible
	Bad magnet on engine	Contact local Honda service center
ELECTRICAL SYSTEM NOT WORKING	Blown or missing fuse	Replace fuse
	Loose or corroded battery connection	Clean and tighten connections
	Worn out or defective battery	Replace battery
	Defective ignition switch	Replace ignition switch
	Bad connection in wire harness	Replace or replace wire harness
ENGINE BACKFIRES	Fouled sparkplug	Replace or clean sparkplug
	Missing or incorrectly installed air intake restrictor	Replace or correctly install air intake restrictor
	Throttle cable is defective or out of adjustment	Clean and oil or replace cable
ENGINE KNOCKS	Engine idle speed too low	Adjust engine idle
	Overloaded engine	Avoid overloading engine
	Stale or dirty fuel	Replace fuel with new fuel
ENGINE SHUTS DOWN WHILE TURNING, ON INCLINES, OR ON UNEVEN TERRAIN	Low engine oil	Check oil level with unit on level ground
	Honda oil sensor is bad	Get Honda low oil sensor changed by authorized Honda service center
STEERING FEELS FUNNY / PULLING TO ONE SIDE / HARD TO STEER (CALL NORMALLY FOR 4WD)	One side may still be engaged in 4WD with the switch off	Put unit in reverse and back up straight a few feet to get the axle to release
	One side may still be engaged in 4WD with the switch off	Take unit to a service center
	Low tire pressure	Inflate tires to proper levels (12 p.s.i. recommended for full size UTVs)
BRAKES DONT WORK WELL / HARD TO PUSH / NO TRAVEL IN PEDAL	Brake rotors are dirty 4WD	Clean rotors with brake cleaner and test. A stiff pedal is normal for a 4WD unit
	Brake rotors are dirty 2WD	Put unit in reverse, back up at low speed and step hard on the brake (2WD units have an auto brake adjuster)
BELT SLIPPING / WILL NOT PULL UPHILL	Too much weight	Lighten load
	The belt is wet	Dry the belt
	Torque converter pulleys are dirty	Clean the torque converter
	Belt may have stretched or have a low spot causing slipping	Replace the belt

Fuel in the Cylinder Cavity (applies only to single cylinder engines)

In the event that the fuel valve is left open while transporting or towing this Utility Vehicle it is possible that fuel has leaked down into the cylinder cavity. If this has occurred the engine will not start. With the cylinder cavity full of fuel the engine will feel like it has “locked up”. Below are the proper steps to follow if your Utility Vehicle engine seems to have fuel in the cylinder cavity.

⚠ WARNING

Use EXTREME CAUTION when performing the activity below. Gasoline is EXTREMELY FLAMABLE!

1. Move the vehicle to a well ventilated area, away from sparks or flame.
2. Park Vehicle on a level surface, set park brake, turn off ignition switch, and remove key.
3. Remove the wire connected to the spark plug. And remove the spark plug from the engine. (See figure 7.1)
4. **WARNING:** Stand away from the spark plug hole when performing step 5. Fuel can spray several feet.
5. Wearing eye protection, slowly pull the recoil start grip handle (See figure 7.2) in an upward motion. This should force the fuel out of the cylinder cavity through the spark plug hole. **Caution: This gasoline spraying out of the cylinder cavity is very flammable, use extreme caution and make sure there are no sparks or flames nearby.**
6. Repeat step 3 until only air escapes out of the spark plug hole.
7. Properly replace the spark plug back into the cylinder head, move the vehicle away from any spilled fuel. If there is fuel on the vehicle itself, allow for it to evaporate before continuing.
8. Connect the plug wire. Your Utility Vehicle is now ready to start.

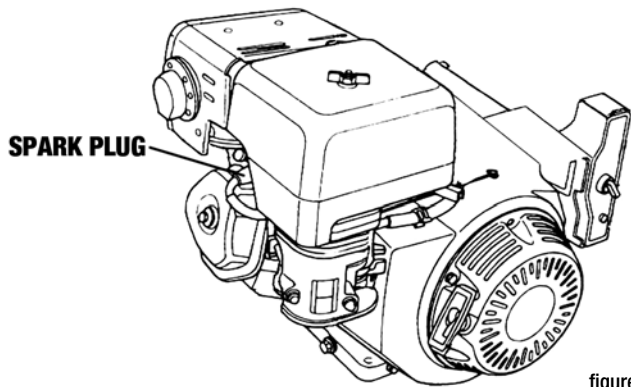

figure 7.1

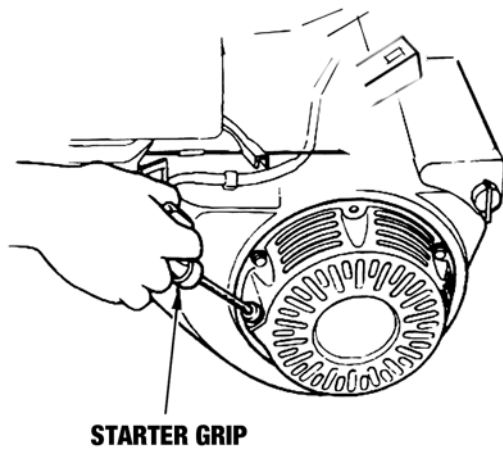

figure 7.2

ASW Utility Vehicle Shifter Trouble Shooting

Notice: Always check transmission oil level. Dip a clean screwdriver straight down in the fill hole to the bottom of the gear case. There should be about 2 ½ inches of oil on the screw driver. If oil needs to be added, use SAE 30 motor oil. See Page 28 for Instructions

- **Engine will not turn over when key is turned to start.**
– This vehicle is equipped with a safety switch that only allows starting in neutral.

Go to **Neutral switch diagnostic procedure** below.

- **Gears grind when going into a gear or vehicle stays in gear when shifted to neutral.**
– Cables need to be lubricated or adjusted.

Go to **Cable adjustment procedure** below.

Neutral Switch Diagnostic Procedure

If starter does not engage when shift lever is in neutral:

1. Apply the parking brake.
2. Turn and hold the key to start. – “Jiggle” the shift lever in the neutral slot. If the starter engages, release the key and call American SportWorks Customer service to order a neutral switch shim kit.
3. If the starter did not engage in step 2, turn and hold the key to start – slowly move the shift lever from neutral to reverse – if the starter engages, release the key. Repeat, moving the shift lever from neutral to forward.

- **If the starter did engage, go to Cable adjustment procedure section.**
- **If the starter did not engage call Customer Service at 1-800-643-7332.**

Cable Adjustment Procedure

Stiff or sticking cables can cause the vehicle to not shift properly and it may affect starting since the vehicle must go to neutral to start. Before attempting to adjust the cables there are several steps that can be taken to insure the cables are operating properly.

- Lubricate the cables. Behind the dash board there are two cables attached to the gear selector lever. Slide the rubber dust caps up the cable. Drip or spray penetrating oil into the cable housing while working the lever. Do this several times as the oil soaks into the housing. Test the vehicle. If this did not help move to the next step.
- Remove the center console (with cup holders). Find the shifter cables and cut the plastic ties that fasten them to the frame tube. Over tight cable ties can cause the cable to bind. Replace cable ties but leave them loose so that the cable can move in them. Test the vehicle. If it is still not performing correctly, move to the adjustment procedures that follow.

1. Put the vehicle in neutral.
2. Loosen the cable adjusters behind the dash board. (figure 7.3)
3. Make sure the selector lever on the dashboard is in neutral.
4. Make sure the transmission is in neutral. You can check by turning the key to Start. The engine will only turn over if the transmission is in neutral.
5. Pull the slack out of both cables (but do not stretch the springs) and tighten the adjuster nuts or you can also use the adjuster nuts on the cable bracket located on the transmission. (figure 7.4)

If you have tried all of this and it is still not operating correctly, you may need new cables. Please call American SportWorks Customer Service at 1-800-643-7332. Have your serial number when you call.

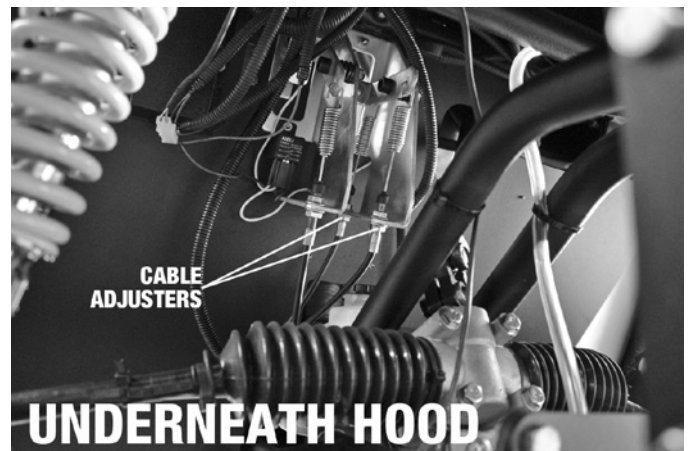

figure 7.3



figure 7.4