

Operator's Manual SUPPLEMENT

MODEL NO.

285-191

285-192

WARNING:
Read Engine
Owner's Manual,
Vehicle Operator's
Manual, and
Supplement
Carefully Before
Operating
Vehicle.

Parts List



(Unit pictured is 285-18)

**THIS VEHICLE IS FOR
OFF-ROAD USE ONLY**

BEFORE OPERATING THIS VEHICLE, THE OWNER AND/OR OPERATOR MUST UNDERSTAND THE VEHICLE WAS NOT DESIGNED OR MANUFACTURED TO MEET SPECIFICATIONS FOR USE ON PUBLIC ROADS, STREETS, HIGHWAYS, OR THOROUGHFARES AND HAVE READ AND HAVE AN UNDERSTANDING OF ALL THE INSTRUCTIONS FOR SAFE ASSEMBLY AND OPERATION AS WELL AS THE INSTRUCTIONS GOVERNING THE ENGINE AND OTHER PORTIONS OF THE VEHICLE.

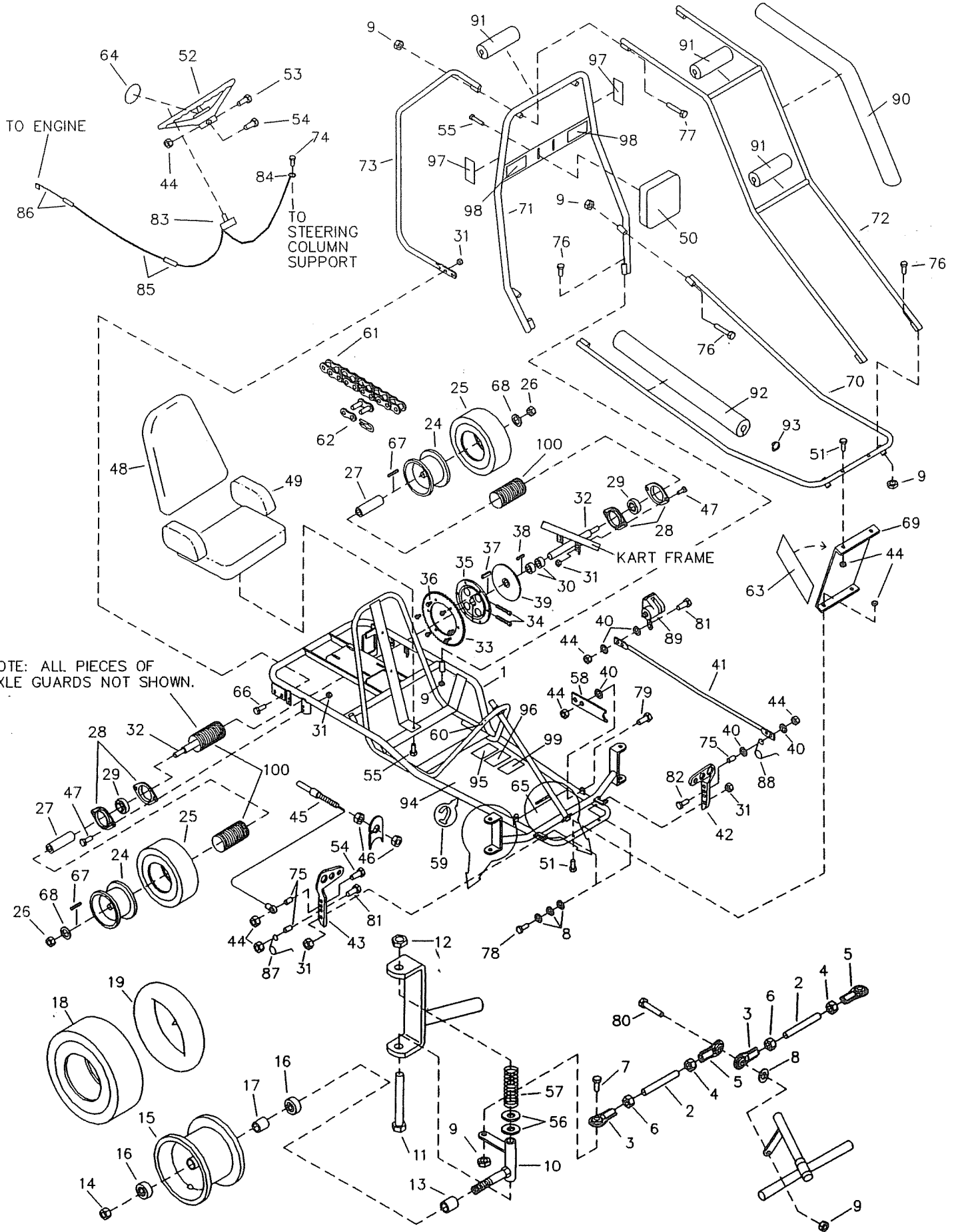

REPAIR PARTS - MODEL 285-191/192

REF. NO.	PART NO.	DESCRIPTION	REF. NO.	PART NO.	DESCRIPTION
	1	9741-19	61	9514	Chain, #420 x 62P (incl. 62)
ASM	1464	Tie Rod Assembly (incl. 2-6)	62	2037	Master Link, #420
2	1465	Tie Rod	63	9341	Decal, Front Plate
3	1415	Rod End - Left Hand Thread	64	5946	Decal, Steering Wheel
4	9092	Nut, 3/8-24 Right Hand Thread	65	1441	Scuff Pad, Floor Pan
5	1414	Rod End - Right Hand Thread	66	9176	Bolt, 5/16-18 x 1"
6	9024	Nut, 3/8-24 Left Hand Thread	67	6123	Key, 1/4" Square x 1-3/4"
7	9146	Bolt, 3/8-16 x 1-1/2"	68	1194	Washer, 3/4" Flat
8	9091	Washer, 3/8 Flat	69	1607	Front Plate
9	9085	Nut, 3/8-16 Lock	70	9748-2	Front Bar
10	2457	Spindle - Right Side	71	9746-2	Center Bar
NI	2458	Spindle - Left Side	72	9749-2	Overhead Bar
11	5682	Bolt, 1/2-13 x 5-1/2"	73	9747-2	Rear Upright
12	1012	Nut, 1/2-13 Toplock	74	9796	Screw, 12-24 x 1/2" Self Tapping
13	5157	Spacer, 5/8" x 3/4"	75	1389	Bushing
14	1046	Nut, 5/8-11 Toplock	76	2386	Bolt, 3/8-16 x 3-1/2"
15	9509P	Fr. Wheel Assembly (incl. 16-19)	77	6452	Bolt, 3/8-16 x 5"
16	5090	Bearing	78	1447	Bolt, 5/16-18 x 1-3/4" Shoulder
17	5950	Spanner	79	1846	Bolt, 1/4-20 x 3/4"
18	4915	Tire, 145/70 x 6" Knobby	80	9145	Bolt, 3/8-16 x 1-3/4"
19	3802	Tube, 6"	81	1847	Bolt, 1/4-20 x 1"
20	_____	_____	82	1848	Bolt, 1/4-20 x 1-1/4"
21	_____	_____	ASM	9799	Stop Switch Asm (incl. 83-85)
22	_____	_____	83	1392	Stop Switch
23	_____	_____	84	1393	Ring Terminal
ASM	3554	Rear Wheel Assembly (incl. 24,25)	85	1394	Wire, 50" with Splice Connector
24	3552	Wheel - 8" Gold	86	1406	Wire, to Engine
25	3548	Tire, 18/9.5 x 8"	87	9502	Spring, Left Wound
NI	1430	Tube, 8" (Repair Part Only)	88	9503	Spring, Right Wound
26	9162	Nut, 3/4-10 Toplock	89	9597	Caliper (see Caliper Breakdown)
27	1448	Spacer, 1" ID x 3-9/16"	ASM	9798*	Foam Replacement Kit (incl. 90-92)
28	1760	Bearing Flange	90	9758*	Foam, 43"
29	3941	Bearing	91	9808*	Foam, 10"
30	2265	Spacer, 1" ID x 3/4"	92	9759*	Foam, 30"
31	1189	Nut, 5/16-18 Toplock	93	9776	Clamp, 3/4"
32	9740	Axle	94	9361	Decal, Floor Pan
ASM	6420	Sprocket Assembly (incl. 33-36)	95	2832	Decal, Warning - No Passengers
33	6282	Sprocket, 54 Teeth 420 Chain	96	4504	Decal, Warning - Yellow
34	6701	Bolt, 5/16-18 Socket Head	97	6540	Decal, Warning: Wear Helmet
35	6280	Sprocket Hub	98	8138	Decal, Warning: Entanglement
36	1876	Bolt, 1/4-20 x 5/8" Whiz	99	8154	Decal, Age Restriction
37	9680	Key, 1/4" x 3/8" x 1-1/4" Long	100	K285-18	Axle Guard Repair Kit
38	1775	Key, 1/4" Square x 1-1/4" Long	NI	2684D	Engine Owner's Manual (285-191)
39	9511	Brake Rotor	NI	2684E	Engine Owner's Manual (285-192)
40	1854	Washer, #14 Flat	NI	6477	Vehicle Operator's Manual
41	9744-2	Brake Rod	NI	9247R4	Assembly Instructions
42	1436	Brake Pedal			
43	1437	Throttle Pedal			
44	9057	Nut, 1/4-20 Toplock			
45	1390	Throttle Cable (incl. 46)			
46	9058	Nut, 5/16-24 Jam			
47	2264	Bolt, 5/16-18 x 3/4"			
48	5159	Seat Back			
49	5160	Seat Bottom			
50	6320	Headrest Pad			
51	1849	Bolt, 1/4-20 x 1-1/2"			
52	6038	Steering Wheel			
53	9080	Bolt, 1/4-20 x 2-3/4"			
54	9160	Bolt, 1/4-20 x 7/8" with Nylock			
55	5839	Bolt, 1/4-20 x 3/4" Whiz Flange			
56	9022	Washer, 1/2" Flat			
57	5681	Spring			
58	1982	Pedal Latch			
59	1019	Ty-Wrap			
60	1463	Bushing, Plastic			

ASM = Assembly

NI = Not Illustrated

* = Specify Black, Pink, White, or Yellow

CALIPER BREAKDOWN

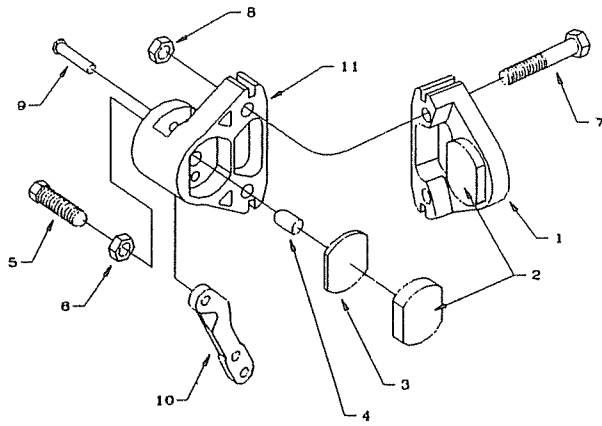

REF. NO	PART NO	DESCRIPTION
ASM	9597	Brake Caliper (incl. 1-11)
ASM	9810	Brake Pad Svc Kit (incl. 1-3)
1	*	Anvil w/Lining
2	*	Brake Lining
3	3928	Backing Plate
4	3930	Actuator Pin
5	3931	Adjuster Pin
6	3932	Nut, Jam
7	9158	Bolt, 3/8-16 x 2-1/4"
8	9085	Nut, 3/8-16 Toplock
ASM	6534	MB-1 Service Kit (incl. 9-11)
9	*	Groove Pin
10	*	Lever
11	*	Brake Housing

TORQUE CONVERTER BREAKDOWN

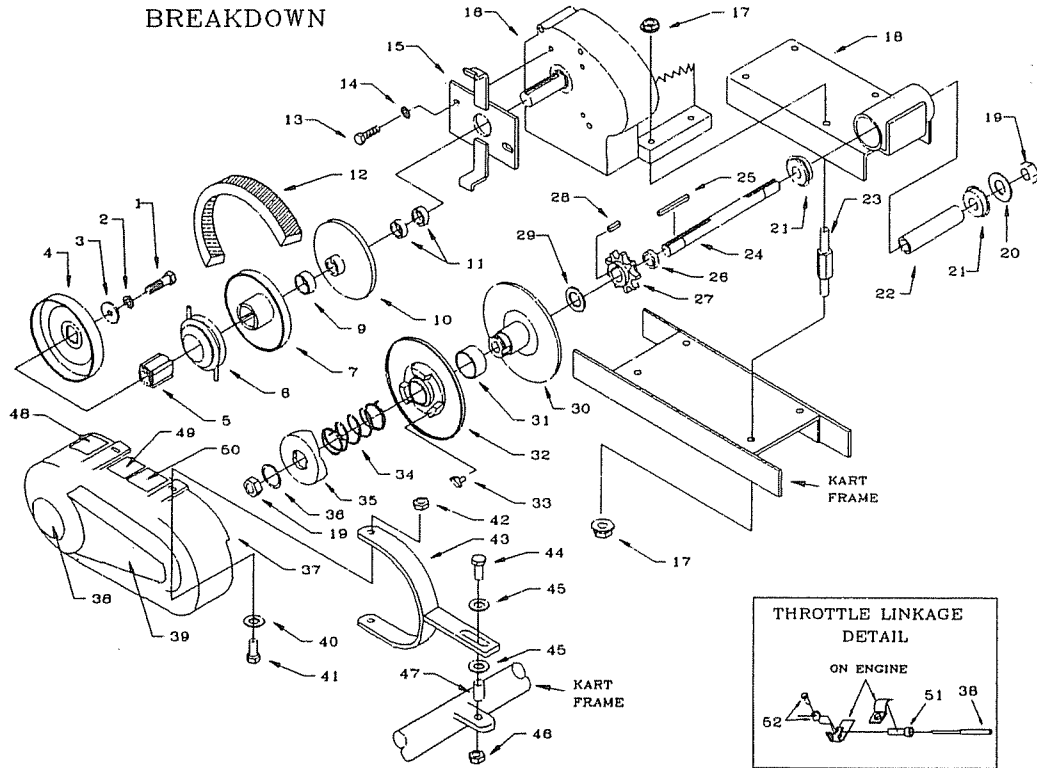

REF. NO	PART NO	DESCRIPTION	REF. NO	PART NO	DESCRIPTION	REF. NO	PART NO	DESCRIPTION
1	1454	Bolt, 5/16-24 x 1.75"	20	1469	Spacer, 5/8ID x .062"	39	9333	Decal
2	1124	Washer, 5/16 Split Lock	21	5090	Bearing	40	2279	Washer, #8 Flat
3	1398	Washer, Flat	22	1116	Spanner	41	2277	Screw, #8 x .5"
ASM	5957	Driver Pulley Assembly (incl. REF. 4-10)	23	1356	Stud	42	2278	Nut, #8 Lock
4	*	Drum	24	1118	Jackshaft	43	1537-2	Bracket
5	*	Hub	25	3403	Key, 3/16sq x 2"	44	1846	Bolt, 1/4-20 x .75"
6	*	Shoe Assembly	26	1937	Spacer, 5/8ID x .25"	45	1854	Washer, 1/4 Flat
7	*	Moveable Sheave	27	1125s	Sprocket, 9T #420	46	9057	Nut, 1/4-20 Lock
9	200349	Bushing	28	1031	Key, 3/16sq x .5"	47	1389	Bushing
10	*	Stationary Sheave	29	1119	Spacer, 5/8ID x .125"	48	6958	Decal, Tire Pressure
11	1442	Spacer, 3/4ID x .250"	ASM	5958	Driven Pulley Assembly (incl. REF. 30-36)	49	4912	Decal, Warning: This Guard...
12	5959	Belt, Asymmetrical	30	*	Stationary Sheave	50	1049	Decal, Warning: ...Drive Cover
13	9101	Bolt, 5/16-24 x .5"	31	*	Bushing	51	1628	Throttle Cable Retainer
14	9030	Washer, 5/16 Interlock	32	*	Moveable Sheave	52	1018	Throttle Cable Stop
15	1494	Mounting Bracket	33	6804	Button, Nylon	NI	9677	Decal, Hot Surfaces
16	9661	Engine, 5hp (285-191)	34	6805	Spring	NI	9678	Decal, Engine Exhaust
	9737	Engine, 5.5hp (285-192)	35	*	Cam	NI	5964	Decal, Oil Warning
17	1263	Nut, 5/16-18 Flange	36	2477	Retaining Ring			
18	1110	Chassis	37	1542	Cover			
19	1136	Nut, 5/8-18 Top Lock	38	1390	Throttle Cable			

* = Not Available Separately
 ASM = Assembly
 NI = Not Illustrated